

TURNING X

*Super High Feed Turning & High Feed Milling
Tool for remarkable improvement of productivity*

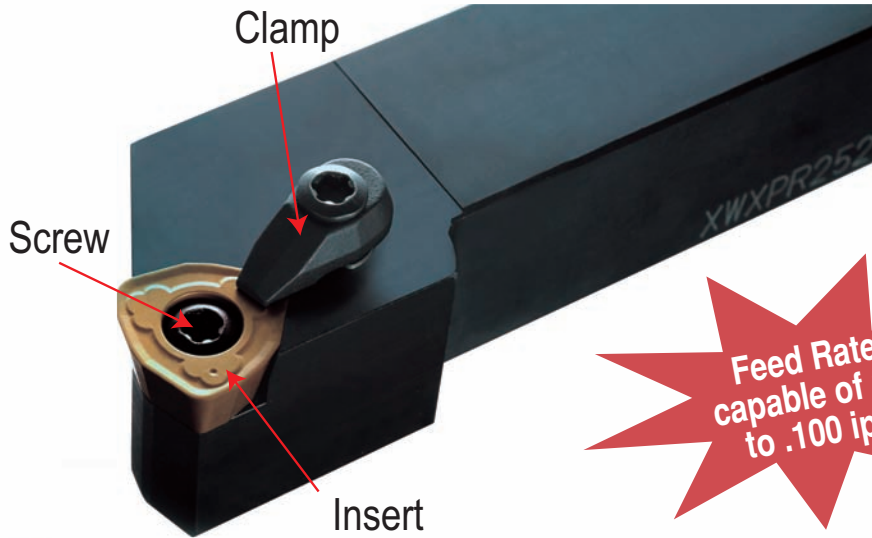

**Feed Rate
capable of up
to .100 ipr**



Material 400 Series Stainless
Cutting Speed 500 sfm
Depth of Cut 0.080"
Feed Rate 0.100 ipr



Material Gray Cast Iron
Cutting Speed 1,000 sfm
Depth of Cut 0.080"
Feed Rate 0.100 ipr

XWXPR/L

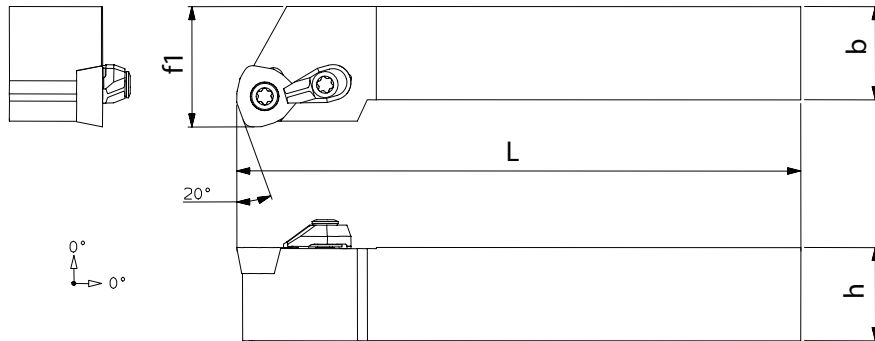

■ Metric

Right/Left Hand	Cat. No. (Metric System)	Insert	Dimensions				Stock
			f1	b	h	L	
Right Hand	XWXPR2525M09	WPMT090725ZPR-ML	32	25	25	150	○
	XWXPR3232P09		40	32	32	170	○
	XWXPR4040S09		50	40	40	200	○
Left Hand	XWXPL2525M09	WPMT090725ZPL-ML	32	25	25	150	○
	XWXPL3232P09		40	32	32	170	○
	XWXPL4040S09		50	40	40	200	○

■ Inch

Right/Left Hand	Cat. No. (Inch System)	Insert	Dimensions				Stock
			f1	b	h	L	
Right Hand	XWXPR16-09	WPMT090725ZPR-ML	1.25	1.00	1.00	6	■
	XWXPR20-09		1.50	1.25	1.25	7	■
	XWXPR24-09		2.00	1.50	1.50	7	■
Left Hand	XWXPL16-09	WPMT090725ZPL-ML	1.25	1.00	1.00	6	■
	XWXPL20-09		1.50	1.25	1.25	7	■
	XWXPL24-09		2.00	1.50	1.50	7	■

■ Inserts

Insert	Grade					
	AH120	AH140	T3030	T1015	T9015	T9025
WPMT090725ZPR-ML	●	●	○		●	●
WPMT090725ZPL-ML	●				○	○